

**GPA-IV Series Energy-saving Pipeline Canned
Motor Pump
Installation and Operation Manual**



Hefei Xihu Canned Motor Pump Co., Ltd

Notes:

1. Read the installation manual carefully before installation and use.
2. The manufacturer will not be liable for any personal injury, pump damage and other property damage due to failure to comply with contents specified in safety warning signs.
3. The installers and operators must comply with local safety regulations.
4. The user must confirm that only qualified personnel with professional certification and proficiency of this manual is allowed to install and maintain this product.
5. The pump must not be installed in a place that is damp or may be splashed by water.
6. For convenient access of maintenance, a shut-off valve shall be installed on each side of inlet and outlet of the pump.
7. The power supply of the pump shall be cut off before installation and maintenance.
8. For circulation of domestic hot water, copper or stainless steel pump body shall be used.
9. Heat supply pipelines shall not be frequently filled with non-softened water so as to avoid increasing calcium in the circulating water inside the pipeline, which may thus block the impeller.
10. Do not start the pump without pumping liquid.
11. Some models are not suitable for pumping drinking water.
12. Pumping liquid may be high-temperature and high-pressure; therefore, the liquid in the system must be completely drained or the shut-off valves on both sides must be closed before moving and dismantling the pump to prevent burning.
13. If removing the exhaust bolt, high-temperature and high-pressure liquid will be overflow. Therefore, it is necessary to guarantee that the outflow liquid will not cause personal injury or damage other parts.
14. Ventilation must be ensured in summer or high ambient temperature period to avoid condensation that may cause electrical malfunctions.
15. If in winter, the pump system does not work or when the ambient temperature drops below 0 °C, liquid in the p
avoid frost cracking of pump body.
16. If the pump is left unused for a long time, please close the pipe valve in the inlet and outlet of the pump and cut off the power supply of pump.
17. If the flexible cord of cable is damaged, it must be replaced by a qualified person.
18. Please close the valve at the inlet of the pump and cut off power of the pump immediately if overheating and abnormality of motor is detected, and contact your vendor or service center immediately.
19. If trouble cannot be addressed according to the manual, please close the valves on the inlet and outlet of the pump immediately, cut off power supply of the pump and contact your vendor or service center immediately.
20. This product shall be put in a place out of reach of children. After installation,

take an isolation measures to avoid access of children.

21. This product shall be stored in a dry, well ventilated and cool place under room temperature.



Warning

Before installation, you must carefully read the installation and operation manual. The installation and use of the equipment must comply with local regulation and applicable operation standards.



Warning

Those who have weak physical strength, react slowly or lack experience and knowledge (including children) can use this motor pump only under the monitoring and direction of his/her safety personnel.

1. Signs



Warning

Failure to comply with this safety instruction may lead to personal injury!

Caution

Failure to comply with this safety instruction may lead to equipment malfunction or damage!

Note

Note or instruction for easy and safe operations

2. General

- 2.1 GPA IVseries circulating motor pump is mainly used in domestic heating and water circulation of domestic hot water system.

The product is most applicable to the following systems:

- stable and variable-flow heat supply system
- variable-temperature pipeline heat supply system
- heat supply system with night mode
- HVAC system
- industrial circulation system
- domestic heating and domestic water supply system

This pump is equipped with permanent-magnet motor and differential pressure controller, capable of automatically & continuously adjusting motor performance to meet the actual needs of system.

This pump is equipped with control panel on the front for easy operation by users.

2.2 Advantages

Easy installation and start-up

- Provided with self-adaptive mode AUTO (Initial setting). In most cases, the motor pump needs no adjustment and can be readily started and automatically adjusted to meet the actual needs of the systems.

High-degree comfort

- Low operational noise of motor pump and whole system

Low energy consumption

- Compared with traditional circulating motor pumps, it has lower energy consumption. GPA series circulating motor pump is attached with Europe Energy Label Class A marking, and the minimum energy consumption can reach up to 5W.

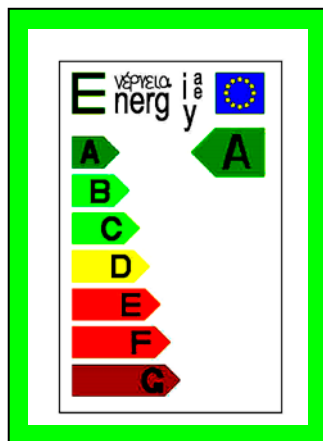

3. Operating Conditions

3.1 Ambient Temperature

Ambient temperature: 0°C ~ +40°C

3.2 Relative humidity (RH) :

Max. humidity: 95%

3.3 Medium (liquid delivery) temperature

To avoid condensation in control box and the stator, the temperature of liquid pumped by the motor pump must be always higher than ambient temperature.

3.4 System Pressure

Maximum pressure 1.0Mpa(10bar).

3.5 Degree of Protection

IP42

3.6 Inlet Pressure

To avoid damage to pump bearing due to cavitation noise, the pump inlet shall maintain the following minimum pressure:

Liquid Temperature	<85°C	90°C	110°C
Inlet Pressure	0.05bar	0.28bar	1bar
	0.5 Head(m)	2.8 Head(m)	10 Head(m)

3.7 Pumping Liquid

The pumping liquid includes thin, clean, non-corrosive and non-explosive liquid which shall not contain any solid particles, fiber or mineral oil, and the pump must definitely not be used to pump inflammable liquid such as rapeseed oil and gasoline. If the circulating pump is used in a place with relatively high viscosity, the pump has lower performance. So when choosing a pump, the viscosity of liquid must be taken into account.

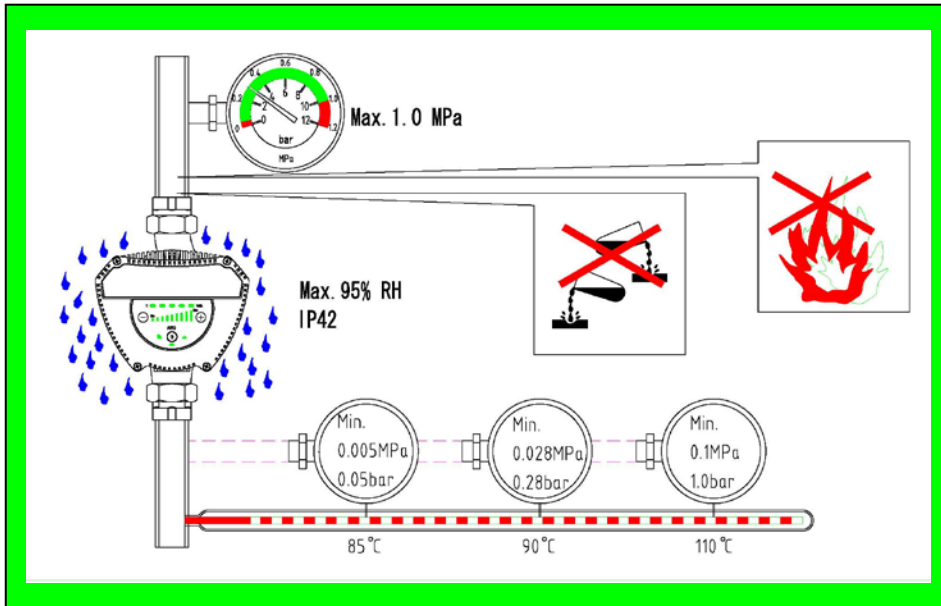

4. Installation

4.1 Installation

- When installing GPA series circulating pump, the arrow on motor pump case indicates the flow direction of liquid through the pump.
- When installing the motor pump in the pipeline, two supplied gaskets must be installed at the inlet and outlet.
- During the installation, the shaft of motor pump must be horizontal.

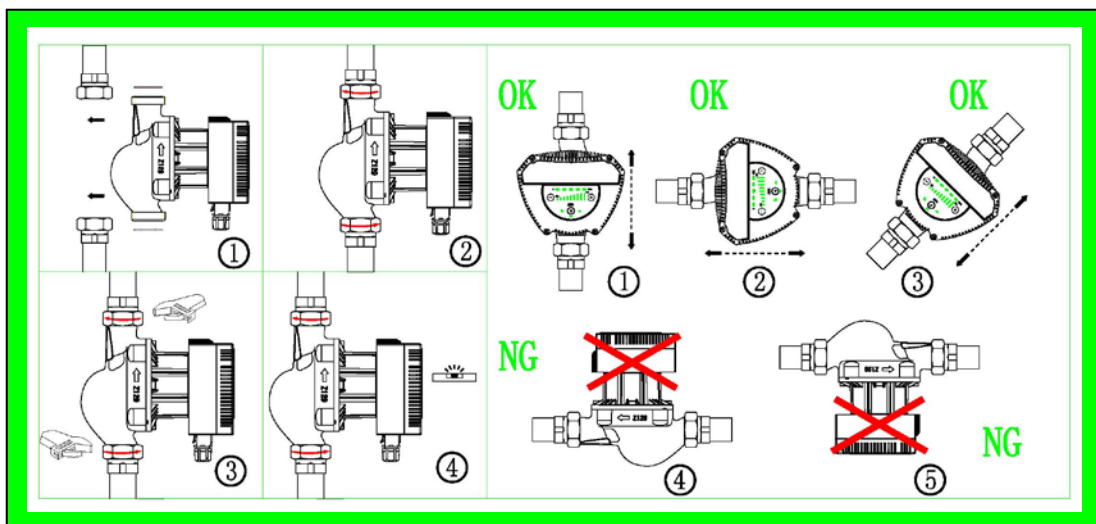

4.2 Position of Junction Box

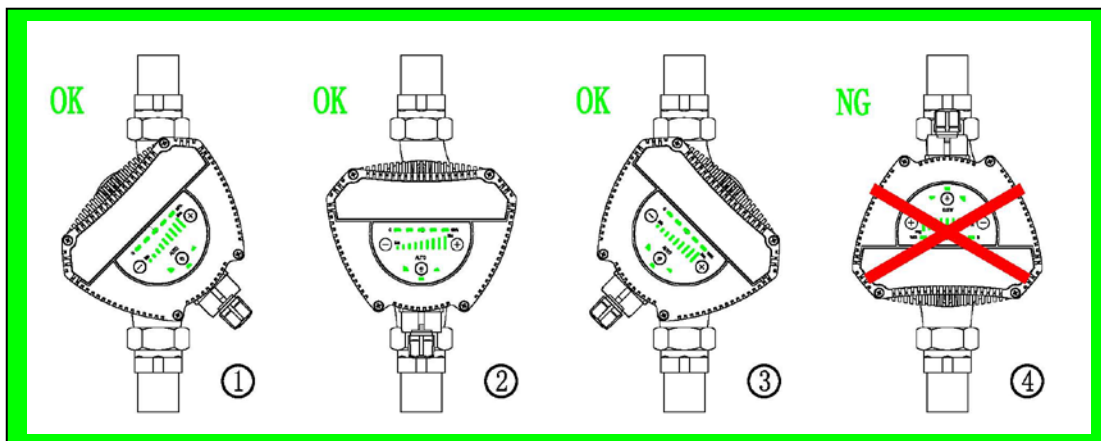

4.3 Changing Position of Junction Box

The junction box can be rotated in a step of 45° .

The procedure for changing the position of junction box are as follows:

1. Close the valves at the inlet and outlet and release the pressure;
2. screw and remove the four socket head screws that fasten the pump body;
3. Rotate the motor to the expected position and align the four screw holes;
4. Install the four socket head screws again and fasten them clockwise;
5. Open the valves at the inlet and outlet.

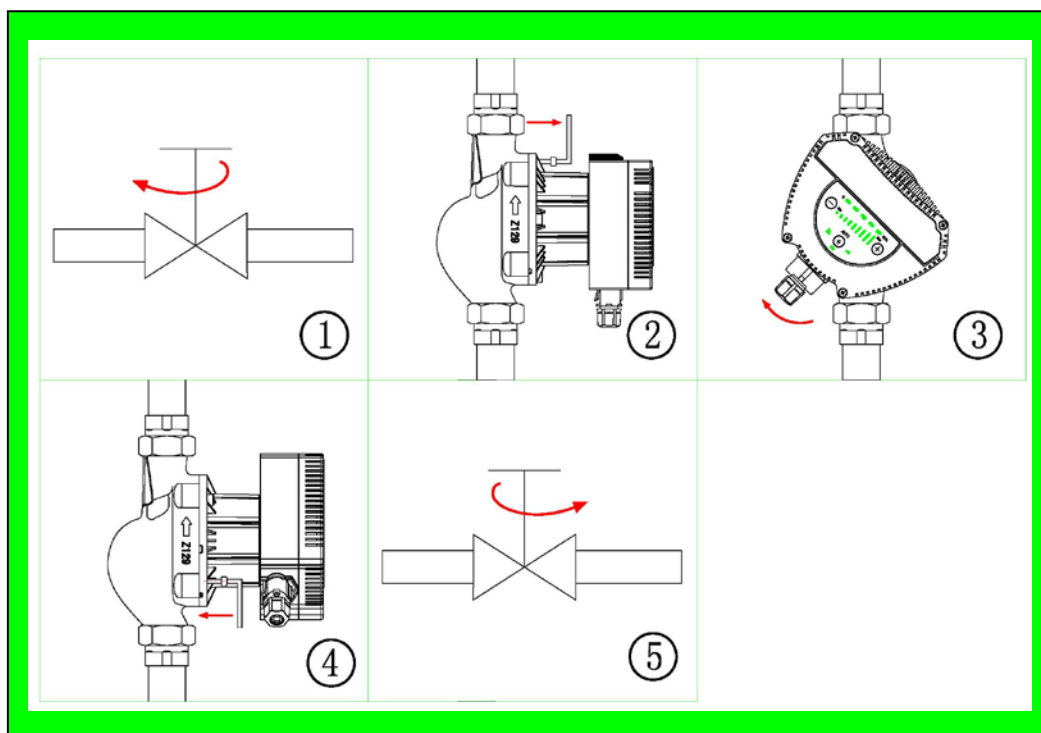



Warning

Pumping liquid may be high-temperature and high-pressure; therefore, the liquid in the system must be completely drained or the valves on both sides of motor pump must be closed before removing the socket head screws.

Caution

When changing the position of junction box, the motor pump can be started only after the system is filled with pumping liquid or the valves on both sides of motor pump are opened.

4. 4 Thermal Insulation of Motor Pump Body

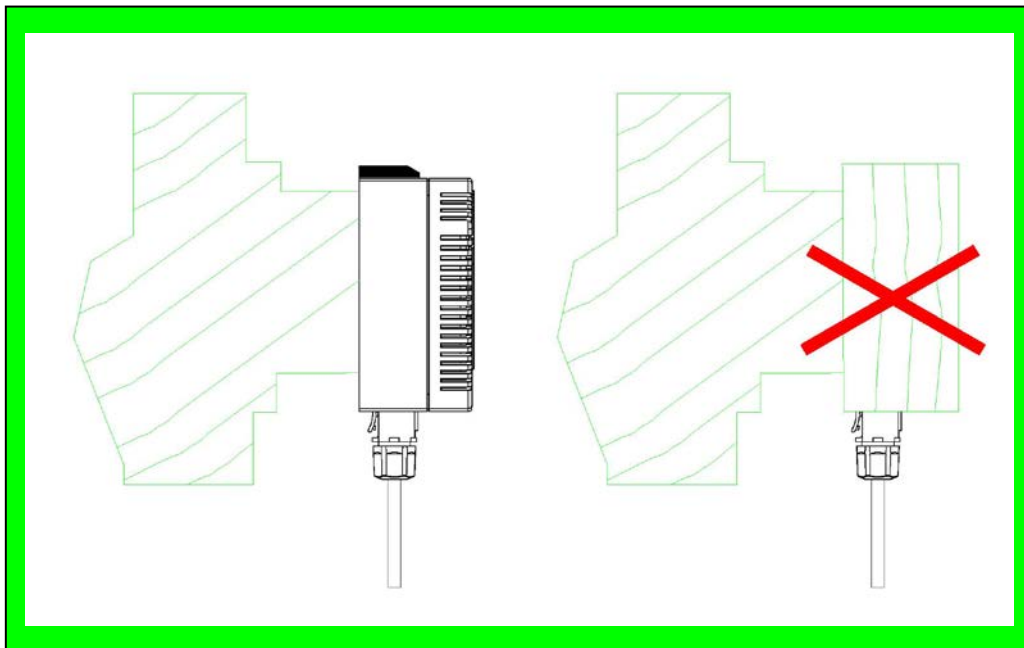

Note

Limiting the heat loss of motor Pump body and pipeline.

Motor pump body and pipeline should be thermally insulated to reduce their heat loss.

Caution

Do not isolate or cover the junction box and control panel.

5. Electrical Connection

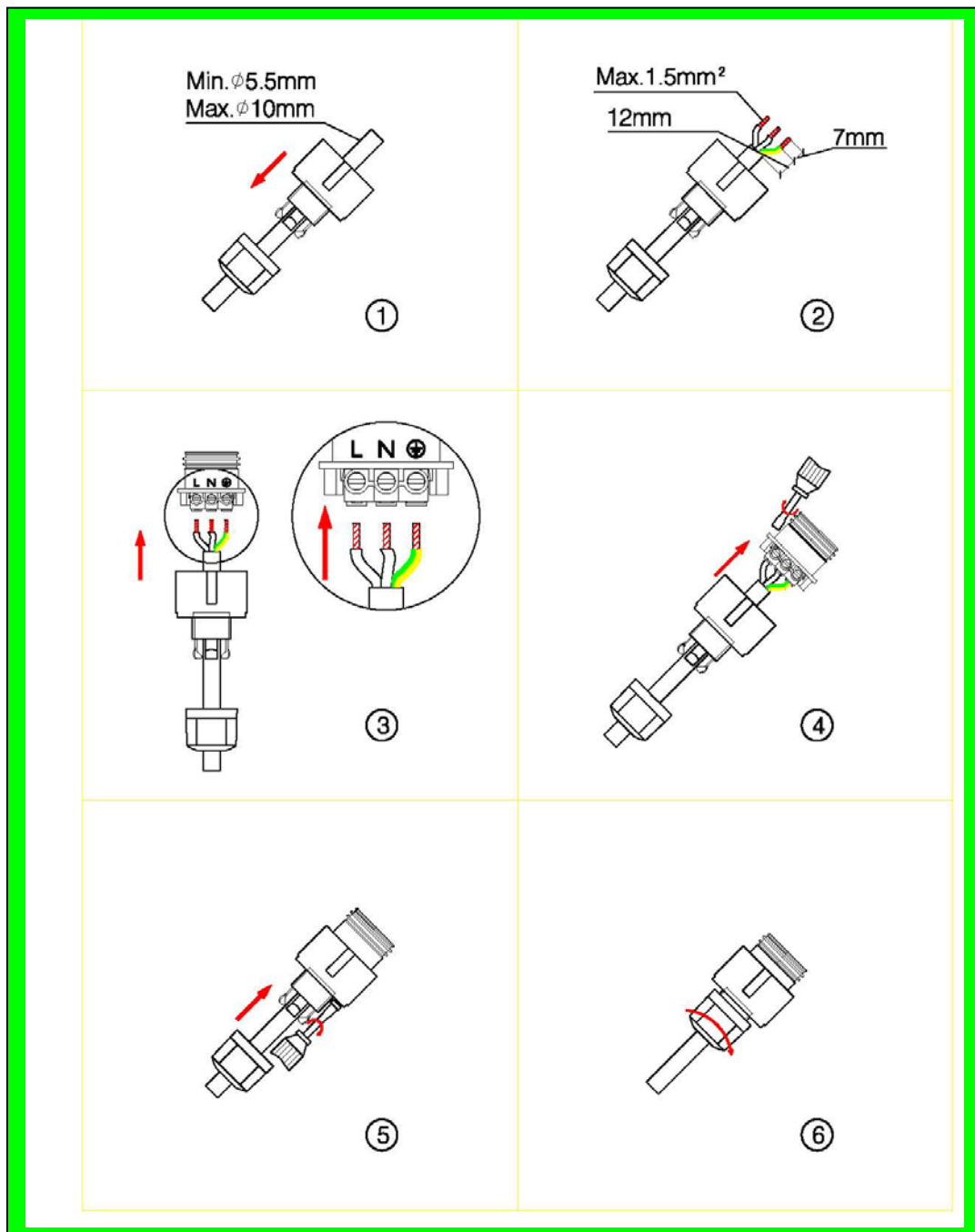

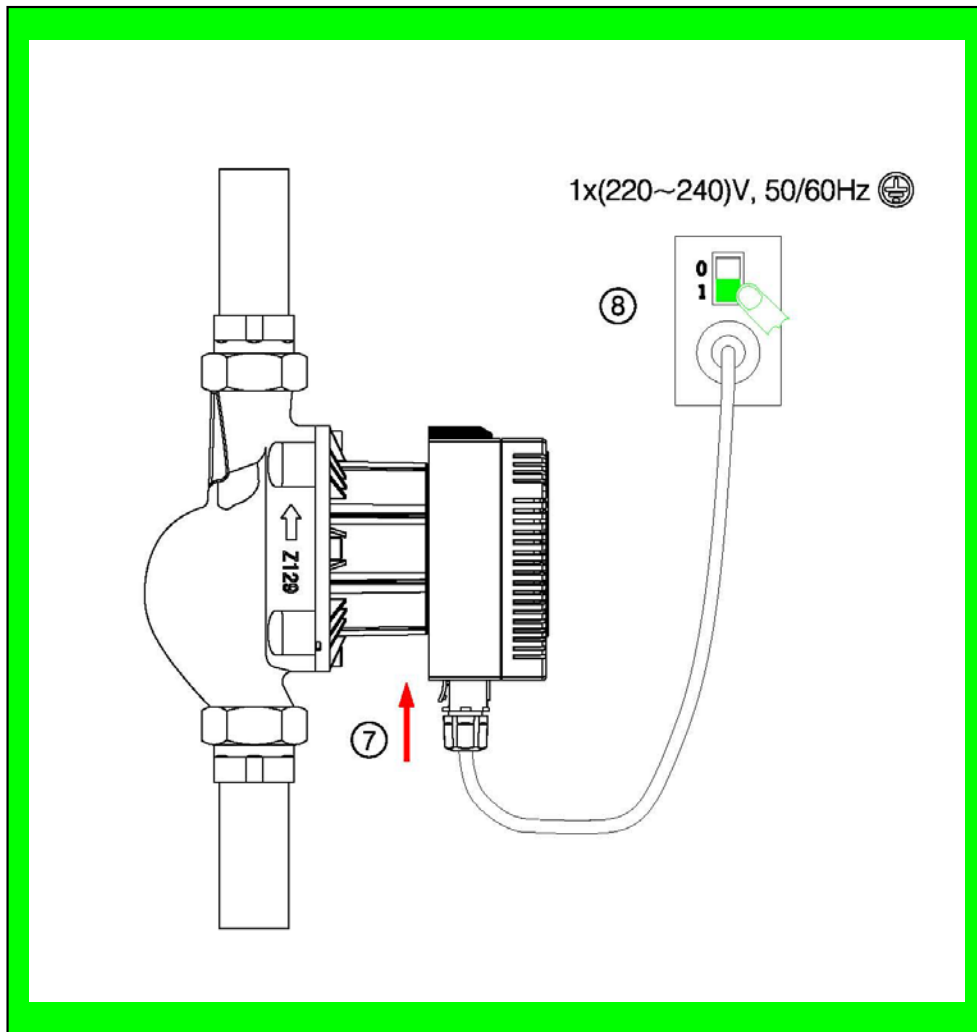

Electrical connection and protection shall comply with local codes and norms.



Warning

The motor pump must be earthed (⊥) .

The motor pump must be connected to an external power switch, and the minimum space between all the electrodes is 3mm.

- GPA IV series circulating motor pump needs no protection from external motor.
- Check if the supply voltage and frequency are the same as parameters indicated on the nameplate of the motor pump.
- Connect the motor pump and power supply with the plug supplied together with the pump.
- After the power is supplied, the indicator lamp on the control panel is ON.

6. Control Panel

6.1 Controls on Control Panel

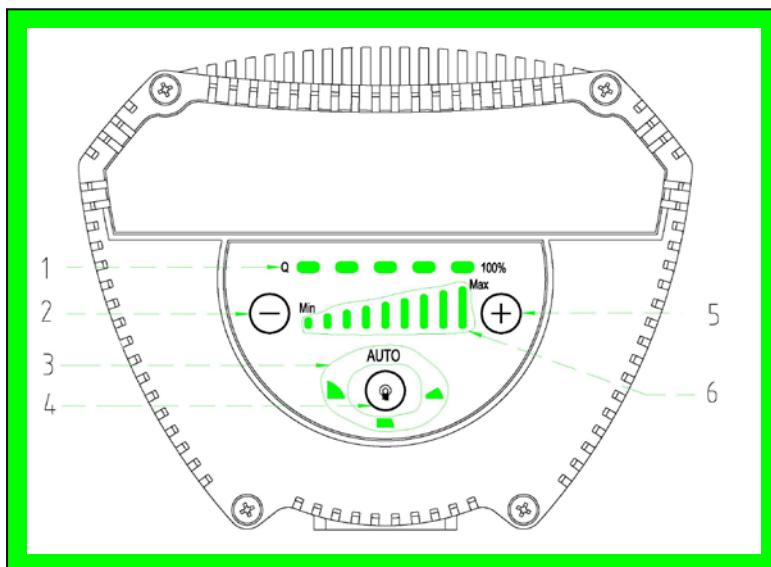

Position	Descriptions
1	Flow rate display during the motor pump is running.
2	Gear reduction button.

3	The lighted area showing the four modes of operation of the motor pump.
4	The setting button for the motor pump operation mode.
5	The button to increase gear.
6	The lighted area showing the gear.

6.2 The showing position of fault code

Fault Code	Fault Description
Gear light 1 flashing	Over-voltage alarm
Gear light 2 flashing	Under-voltage alarm
Gear light 3 flashing	Over-current alarm
Gear light 4 flashing	Loss-phase alarm
Gear light 5 flashing	Start-up fault, Start-up and run blocked
Gear light 6 flashing	Low-power fault
Gear light 7 flashing	Over-temperature alarm

If malfunction is detected, the power supply must be cut off before trouble-shooting. After the trouble is addressed, re-connect the power and start the motor pump.

6.3 Indication Lamp Area of Motor Pump Setting

The GPA IV series motor pumps have 28 settings and can be selected at the push of a button.

The motor pump settings are represented by 13 different light areas.

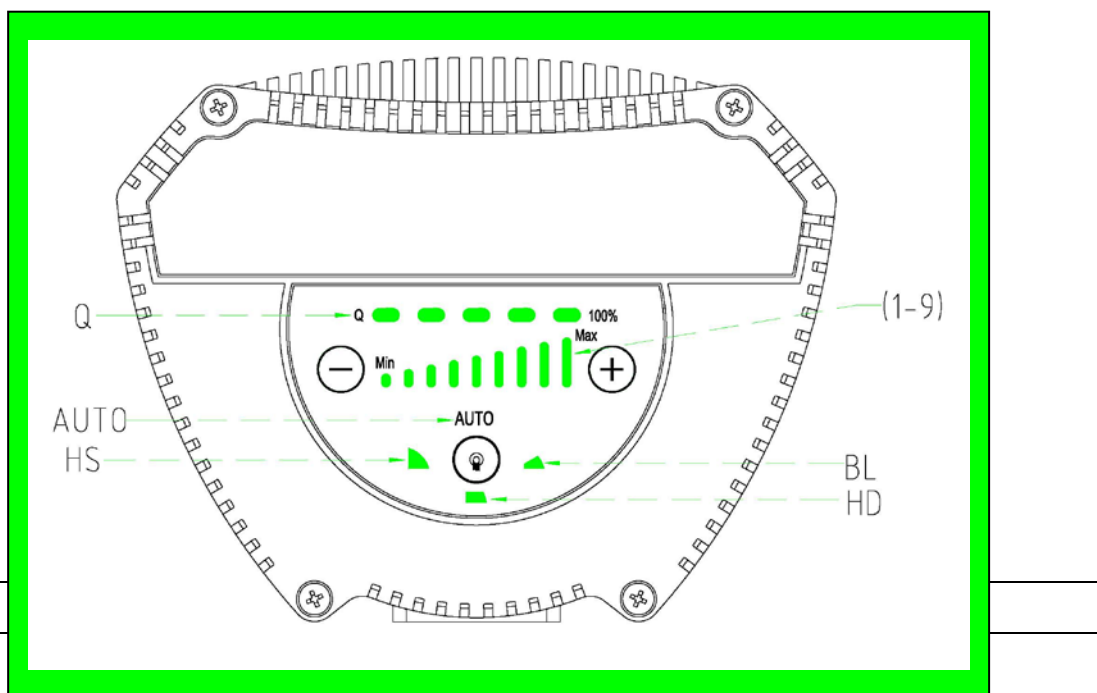

Button Count	Light Area	Descriptions
0	AUTO	Self- adaptive
1	BL (1-9) (Proportional pressure)	Proportional pressure curve
2	HD (1-9) (Constant pressure)	Constant pressure curve
3	HS (1-9) (Constant speed)	Constant speed curve

6. 4 Button for selecting motor pump settings

By pressing the button once at 2 seconds interval, the motor pump setting mode will change once.

A cycle is constituted of every four presses on the button. For details, please refer to Section 6.2.

7. Motor Pump Setting

7. 1 Motor Pump Setting Based on System Type

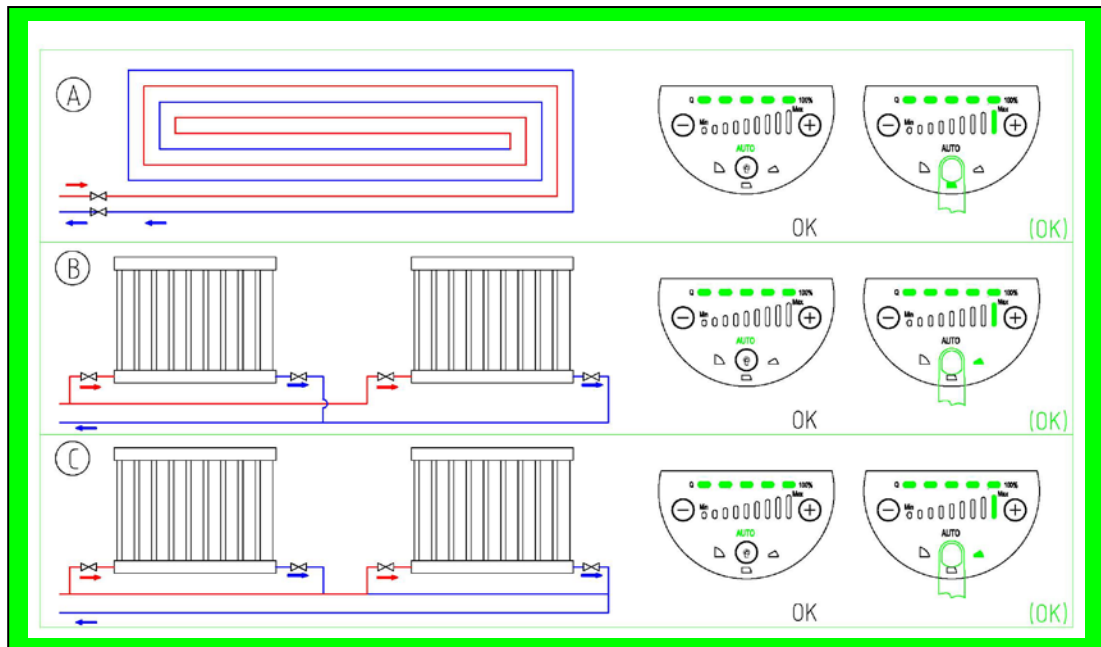

Initial setting= AUTO (Self-adaptive mode)

Recommended and available motor pump setting

Position	System Type	Motor Pump Setting	
		Recommended	Options
A	Underfloor heating system.	AUTO	HD (1-9)
B	Dual line heating system.	AUTO	BL (1-9)
C	Single line heating system.	BL1	BL (1-9)

- AUTO (Self Adaptive Mode) mode can adjust the performance of motor pump based on the actual heat demand of the system. As the performance is adjusted gradually, it is suggested, before changing motor pump setting, to maintain AUTO (Automatically Adaptive Mode) mode setting for at least one week.

- If you select to change back to AUTO (Self Adaptive Mode) mode, the GPA series motor pump can memorize its last setting in AUTO mode and continue adjusting the performance automatically.

- It may take several minutes or even hours to reach the optimal operation mode after motor pump setting is changed from the optimal setting (the “Recommended abovementioned”) to other optional setting. If the optimal setting of motor pump fails to enable each room to obtain desired heat distribution, then you should change the motor pump setting to other settings

- Please refer to Section 12.1 for the relations between motor pump setting and performance curve.

7.2 Control of Motor Pump

When the motor pump is working, the motor pump is controlled according to the principle of “Proportional Pressure Control (BL)” or “Constant Pressure Control (HD)”.

In these two control modes, the motor pump performance and corresponding power consumption will be regulated according to the heat demand of the system.

Proportional Pressure Control

In this control mode, the differential pressure of both ends of the motor pump will be controlled by the flow rate. In the Q/H Figure, proportional pressure curve is represented with BL(1-9). Please refer to Section 11.3.

Constant Pressure Control

In this control mode, the differential pressure of both ends of the motor pump remains constant and is irrelevant to the flow rate. In the Q/H Figure, constant pressure curve is a horizontal performance curve represented with HD1(1-9). Please refer to Section 11.3.

PWM Control

PWM Control Curve

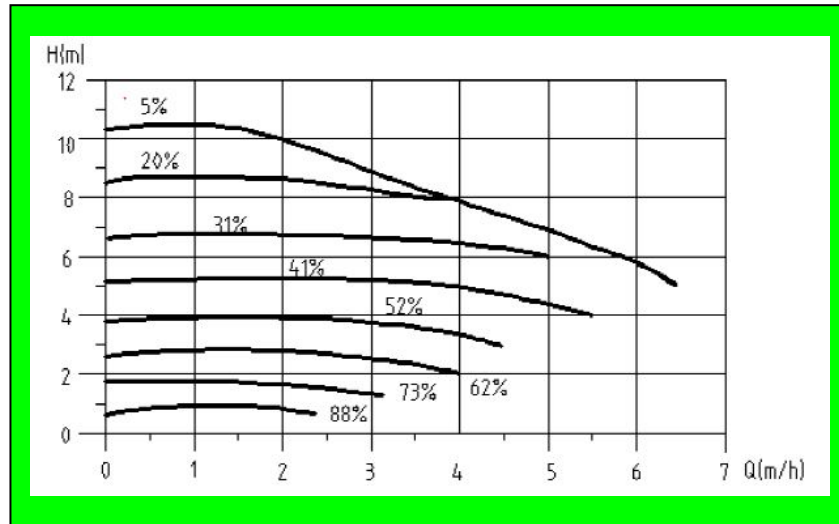

PWM Control Principle

1) Control Principle

The pump is controlled by PWM(Pulse Width Modulation) digital signal, which means that the variance of velocity depends on the external input signal. The variance of velocity is one of the functions of input control.

2) Digital LV PWM (Pulse Width Modulation) Signal

The frequency of PWM signal is 100Hz~4000Hz;

PWM input signal (PWM IN) is used to give velocity commands, and adjusts the speed through adjusting PWM duty cycle;

PWM output signal (PWM OUT) is the feedback signal of the pump, and the PWM frequency is 75Hz.

3) Duty Cycle

$$d\% = t/T$$

For example:

$$T = 2 \text{ ms (500Hz)}$$

$$t = 0.6 \text{ ms}$$

$$d\% = 100\% \times 0.6/2 = 30\%$$

$$U_{iH} = 4 \sim 24V$$

$$U_{iL} \leq 1V$$

$$I_{iH} \leq 10mA$$

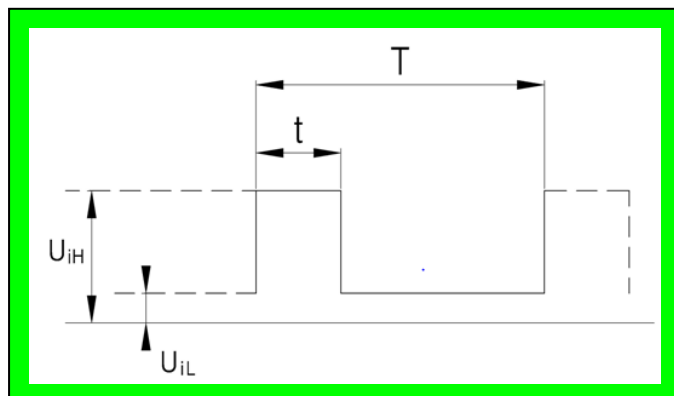

Variable	Descriptions
T	Cycle

d	Duty Cycle
U _{iH}	Input High Voltage
U _{iL}	Input Low Voltage
I _{iH}	Input Current

Note “Signal Ref” is a reference grounded, and it is not connected to protective grounded.

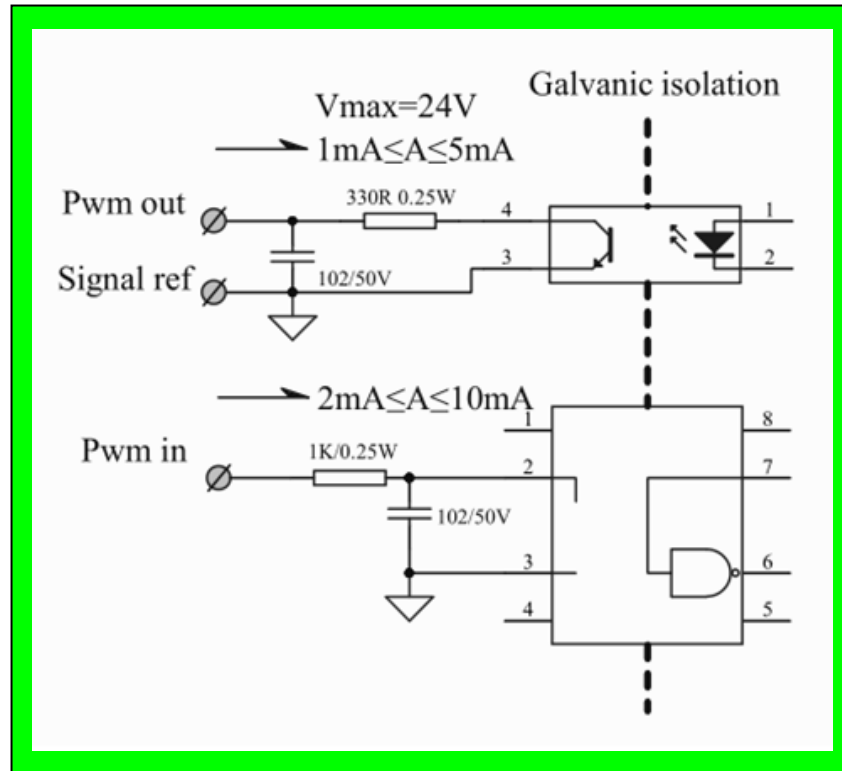

Interface

The pump is controlled by external electrical elements and components through interfaces. The interfaces convert external signals into signals that can be recognized by microprocessor in the pump. In addition, when the pump is supplied with 230V voltage, the interfaces can ensure that users will not be at risk of high voltage electric shock when contacting the signal cable.

PWM Input Signal

- In area of high duty-cycle PWM signal, when the input signal fluctuates in the critical point, there will be a delay area to prevent frequent stop and start of the pump.
- In area of low duty-cycle PWM signal, the pump runs at high speed for the sake of system safety. For instance, when the signal cable of gas boiler system is damaged, the pump will continue to run at the maximum rotational speed and transfer heat through main heat exchanger. This is also applicable to heat pump, ensuring continuous heat transfer in the case of signal cable of pump is damaged and system safety is guaranteed.

- When PWM input signal is 0% or 100%, the pump will switch to non-PWM mode (normal mode), and the default system will have no PWM signal input.

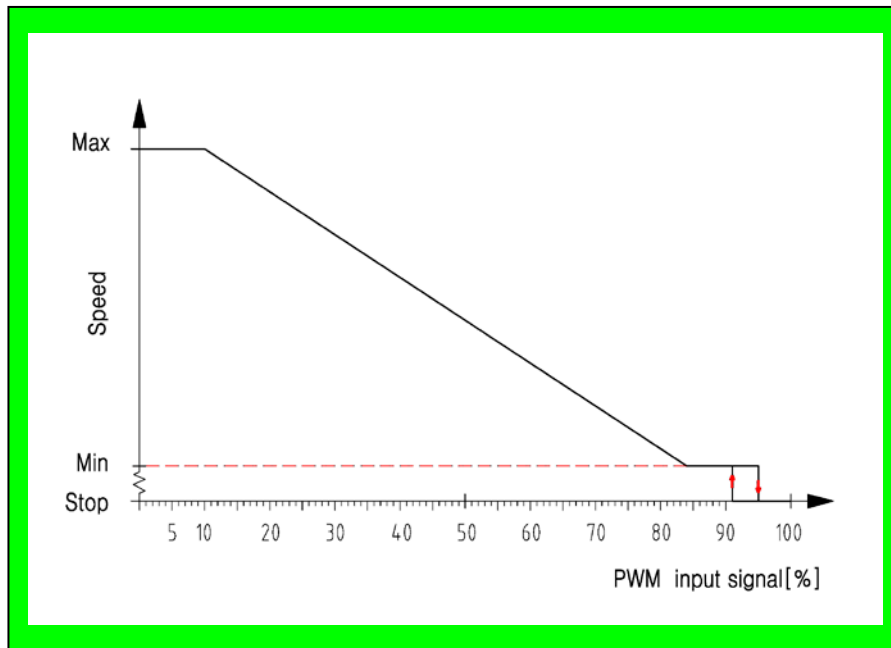

PWM input signal (%)	Pump operation status
0	Pump switches to non-PWM mode and system acquiesces there is no PWM signal input.
<10	Pump runs with highest rotation speed.
10~84	Pump rotation speed decreases from highest to lowest.
85~91	Pump runs with lowest rotation speed.
91~95	Low PWM signal, clocking of the pump is avoided by a hysteresis function.
96~99	Stand-by, pump stops running.
100	The pump switches to non-PWM mode operation (normal mode) the system has no PWM signal input by default.

This system is adaptive to the automatic switching of PWM and non-PWM mode. When there is PWM signal input, the system will enter PWM mode.

PWM Feedback Signal

PWM feedback signal can provide operation status of the pump, such as power loss or all kinds of alarm/warning modes. PWM feedback signal will feed back exclusive alarming information. If the power voltage detects under voltage signal values, its output signal will be set to 75%. Provided sundries settlement exists in the hydraulic system and causes rotor being blocked, the duty cycle of output signal is set to 90%, the alarm will be given higher priority.

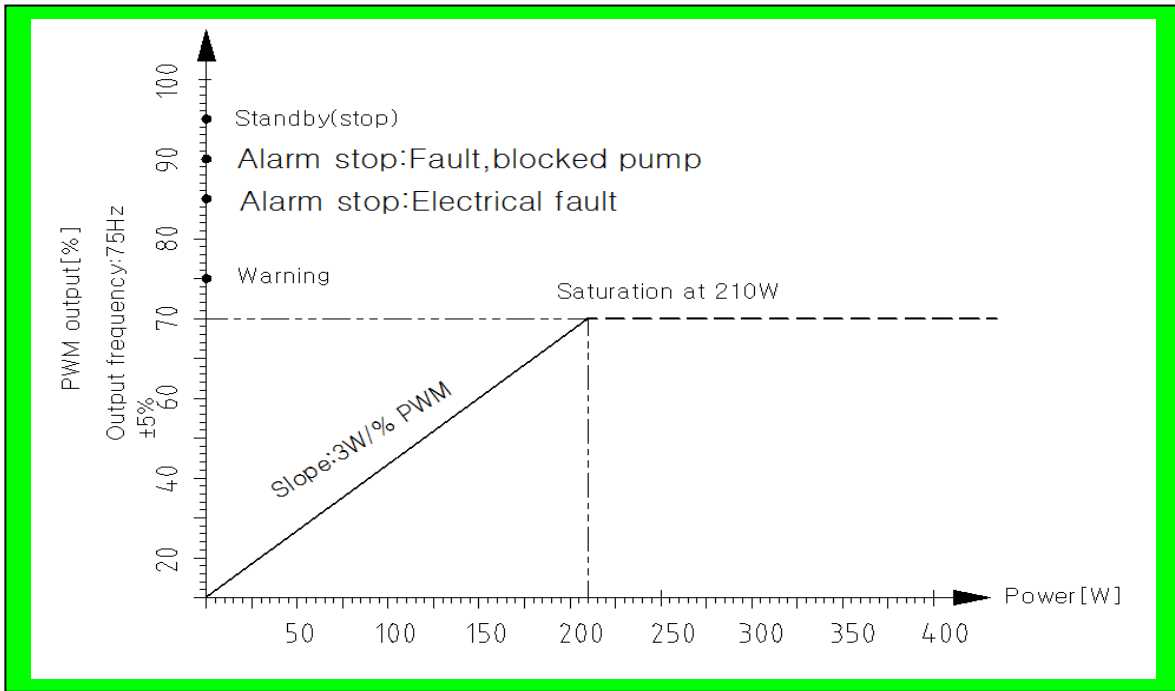

PWM output signal(%)	Pump status	Description
95	Stand-by	The pump stops
90	Pump stops caused by alarm. Malfunctions (pump blocked).	The pump does not work and will restart only after trouble is addressed.
85	Pump stops caused by alarm, electrical malfunction.	Pump does not work and will restart only after trouble is addressed.
75	Alarm.	Pump runs, trouble has been detected. The trouble/malfunction is not critical, and the pump can still work.
0-70	0-210W (slope 3W/% PWM)	

0~10V Control

0-10V analog control signal description: The pump starts to be powered on in the normal mode (constant speed mode or constant pressure mode or proportional mode or AUTO mode), and the factory default constant speed mode. Once there is 0~10V analog voltage input, the pump will enter the 0~10V analog control mode. In this mode, input different analog voltages, the pump will be in different operating states. If the cable is broken in this mode, the pump will run at the lowest speed (The lowest speed in 0~10V analog control mode). Once the pump enters the 0~10V analog control mode, it cannot switch to the normal mode. If you want to enter the normal mode again, you must power on again to enter the normal mode.

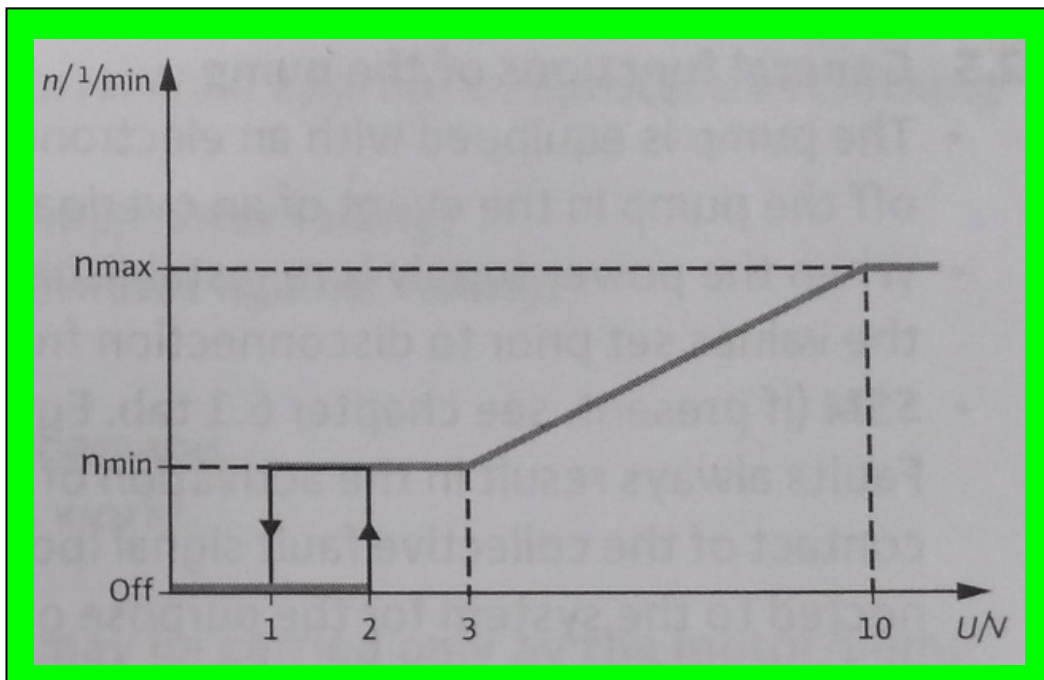

input signal (V)	Pump status
$U < 1V$	The pump stops
$1V < U < 3V$	The pump runs at the lowest speed (when the analog voltage signal changes from large to small, when the voltage value is less than 1V, the pump stops; $>1V$, the pump runs at the minimum speed. When the voltage signal changes from small to large, when the voltage is less than 2V, the pump will stop; when it is more than 2V, it will run at the lowest speed.)
$3V < U < 10V$	Pump at minimum and maximum speed (linear).

8. Bypass valve system installed between the Inlet pipeline and return pipeline

8.1 Purposes of bypass valve

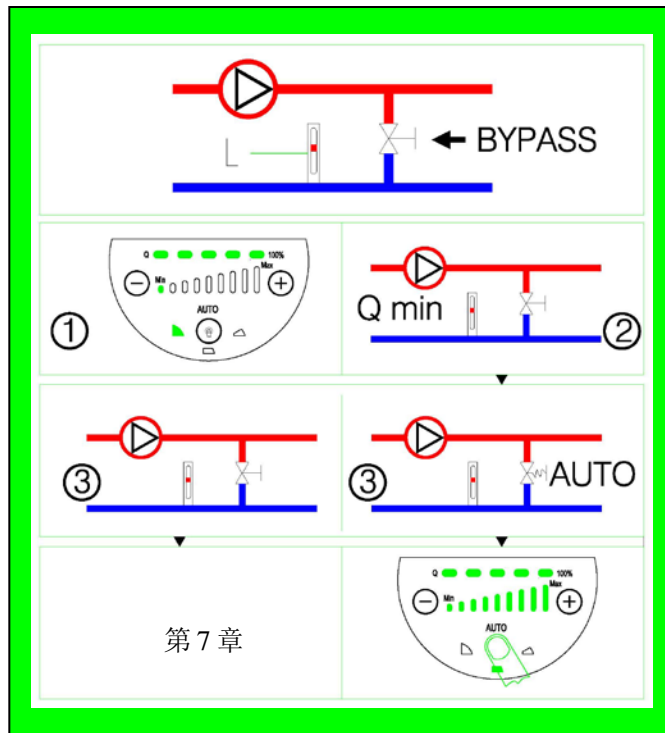

Bypass valve

The purpose of bypass valve: when all the valves and/or temperature-sensing valves of heat radiator in the floor heating loop are closed, it can ensure that the heat from boiler can be distributed.

Elements in the system:

- bypass valve
- flow meter, position L.

When all valves are closed, the minimum flow rate must be guaranteed.

The setting of pump position depends on the type of bypass valve, i.e. manual bypass valve or temperature-sensing bypass valve.

8.2 Manually-operated Bypass Valve

In accordance with the following procedures:

1. The pump should be set in HS1 (constant gear 1 mode) when the bypass valve is adjusted.

The minimum flow rate (Q_{min}) of the system shall be always guaranteed. Please refer to bypass valve manual provided by the manufacturer.

2. After the regulating of bypass valve completes, set the pump in accordance with Section 10.1 of Pump Setting.

8.3 Automatic Bypass Valve (temperature-sensing type)

Follow the following procedures:

1. The pump should be set in HS1 (constant gear 1 mode) when the bypass valve is adjusted.

The minimum flow rate (Q_{\min}) of the system shall be always guaranteed. Please refer to bypass valve manual provided by the manufacturer.

2. After the regulating of bypass valve completes, set the pump to lowest or highest constant pressure mode. For the relations between pump setting and performance curve, please refer to Section 10.1 of Pump Setting and Pump Performance.

9. Start up

9.1 Before Start Up

Before starting the motor pump, ensure that the system is filled with liquid, air has been completely exhausted, and the inlet of motor pump must reach minimum inlet pressure. Please refer to Chapter 3.

9.2 Exhaust the Motor Pump

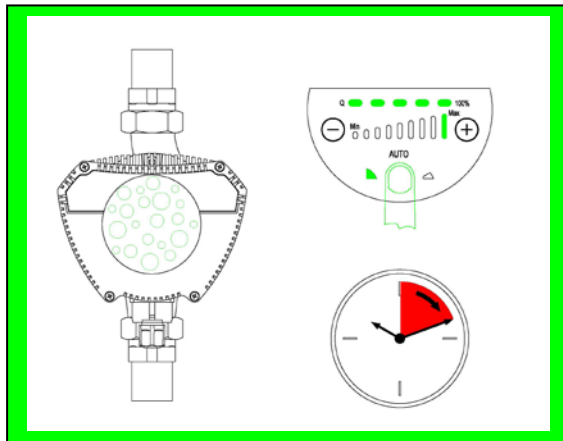

GPA IV series motor pump is equipped with self-venting function. Before the start up, it is not necessary to vent the air. Air in the motor pump may cause noise. After the motor pump is put into operation for several minutes, the noise will disappear.

Based on the system scale and structure, set the GPA series motor pump to Velocity III for a short period of time and air in the pump can be quickly vented.

After air is vented from the motor pump and noise disappear, set the

motor pump in accordance with the manual. Please refer to Chapter 7.

Caution

Motor pump cannot run in idle speed without pumping liquid.

9.3 Vent the heating system

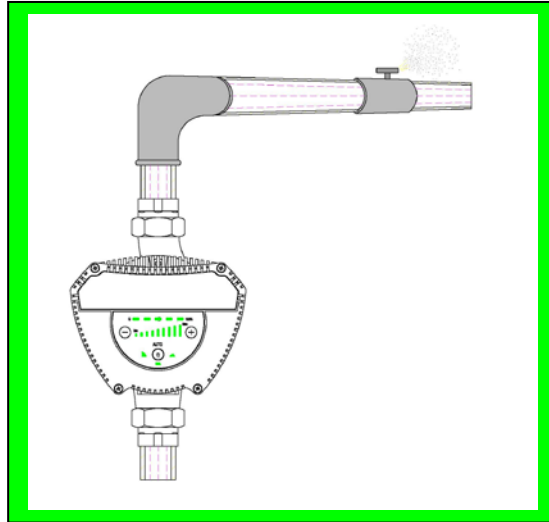

10. Motor Pump Setting and Performance

10.1 Relations between Motor Pump Setting and Performance

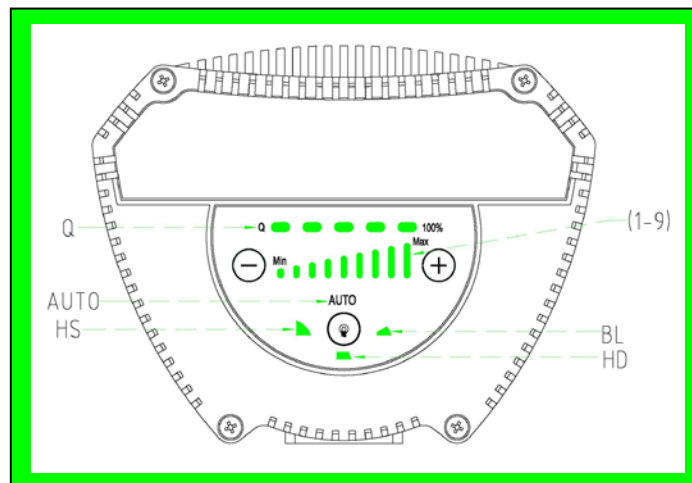

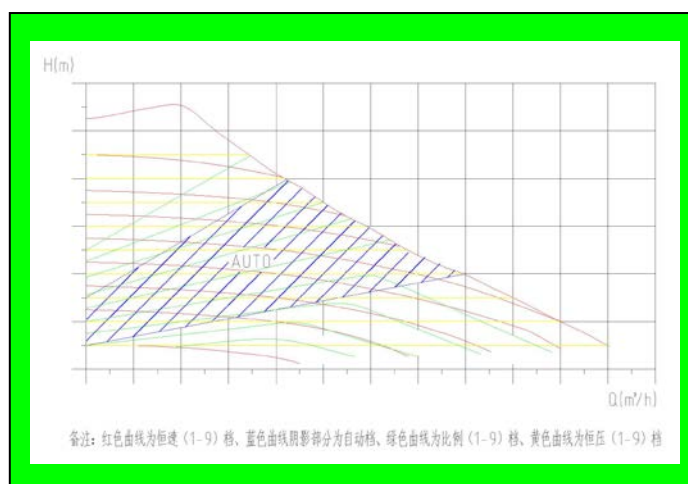

11. Performance Curve

11.1 Guide on Performance Curve

Every setting of the motor pump has corresponding performance curve (Q/H curve). However AUTO (Self Adaptive Mode) mode covers just one performance scope.

Setting	Pump Characteristics Curve	Functions
AUTO (Initial Setting)	曲线 Highest to Lowest Proportional Pressure Curve	AUTO function will automatically control the pump performance within the specified scope. <ul style="list-style-type: none"> • adjust pump performance based on system scale; • adjust pump performance based on load variance within a period of time; Under the AUTO mode, the pump will be set to proportional pressure control;
BL (1-9) (Proportional pressure)	Proportional Pressure Curve	The operating point of the pump will move up and down on the lowest proportional pressure curve based on the demand of system flow rate. When flow demand decreases, the pressure supply of pump drops; when flow demand increases, the pressure supply of pump rises.
HD (1-9) (Constant pressure)	Constant Pressure Curve	The pump operating point will move on the constant pressure curve according to the system flow requirements. The pump supply pressure is kept constant, independent of the flow demand.
HS (1-9) (Constant speed)	Constant Speed Curve	The pump follows a constant curve and runs at a constant speed. In HS mode, the pump is set to run in all working conditions with reference to the largest curve. For a short period of time, the pump is set to HS9 mode allowing for quick venting of the pump.
Q (0-100%) (Flow display)	Flow Display	The percentage of flow is displayed when the pump is running.

The input power curve (P1 curve) belongs to every Q/H curve. Power curve represents the power consumption of motor pump in given Q/H curve with Watt as the unit.

11. 2 Curve conditions

The followings are applicable to the performance curve specified in the GPA series manual:

- Test liquid: air-free water.
- Applicable density of curve $\rho=983.2 \text{ kg/m}^3$, and liquid temperature $+60 \text{ }^\circ\text{C}$
- All curves represent averaged value, and shall not be used as guarantee curve. If a specific performance is needed, then separate measuring shall be conducted.
- The applicable Kinetic viscosity of the curve $\nu=0.474 \text{ mm}^2/\text{s}$ (0.474CcST)

11. 3 Performance Curve GPA IV Series

- Constant speed and auto mode performance curve

GPAXX-6 IV Constant Speed and Auto Mode Performance Curve

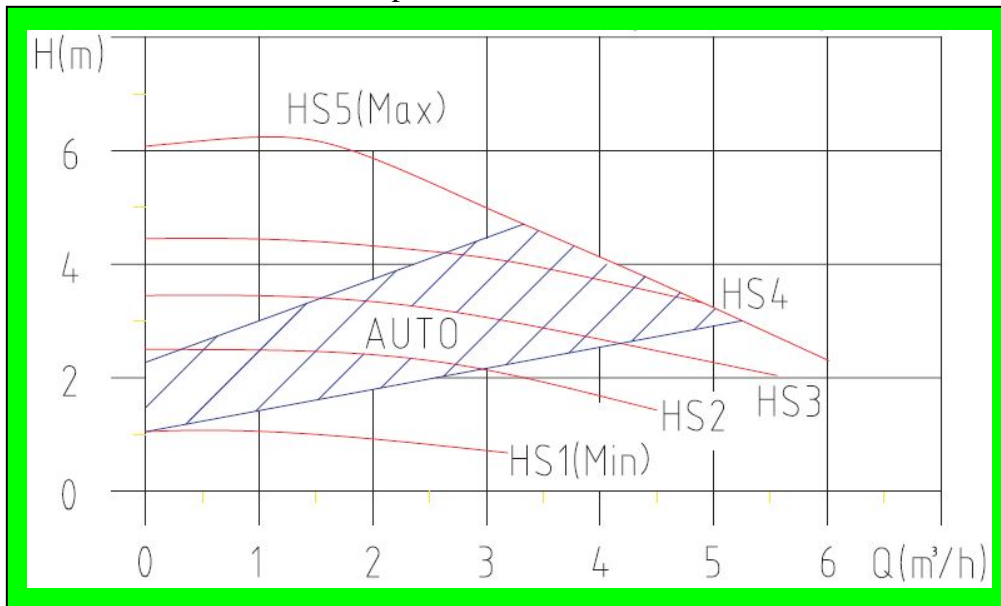

GPAXX-8 IV Constant Speed and Auto Mode Performance Curve

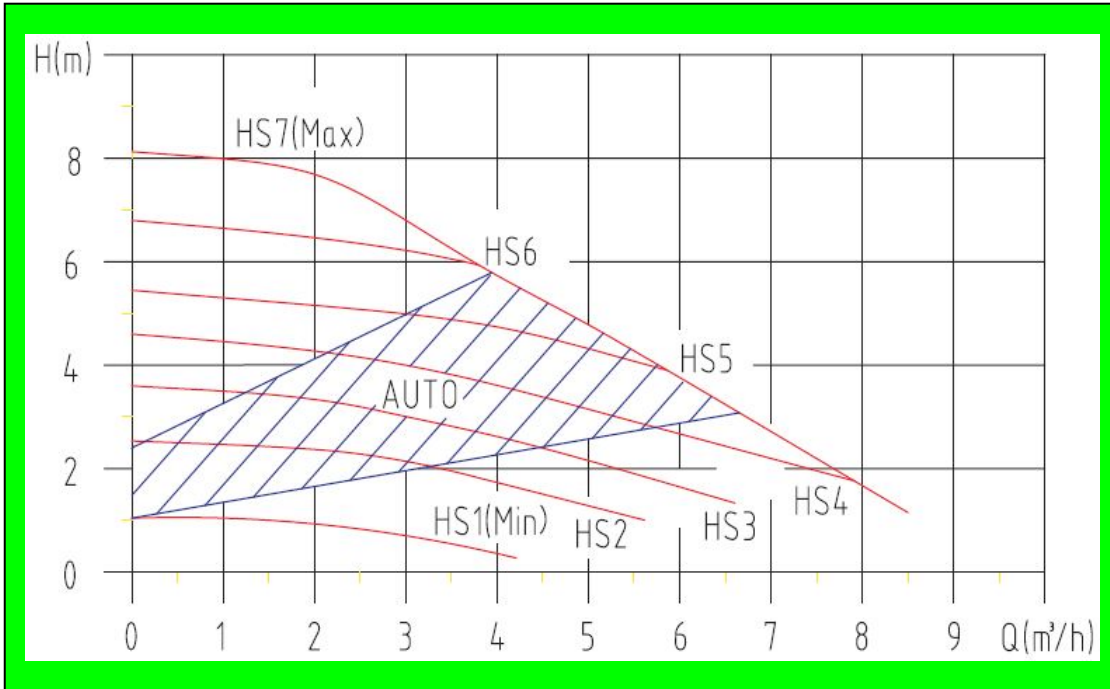

GPAXX-10 IV Constant Speed and Auto Mode Performance Curve

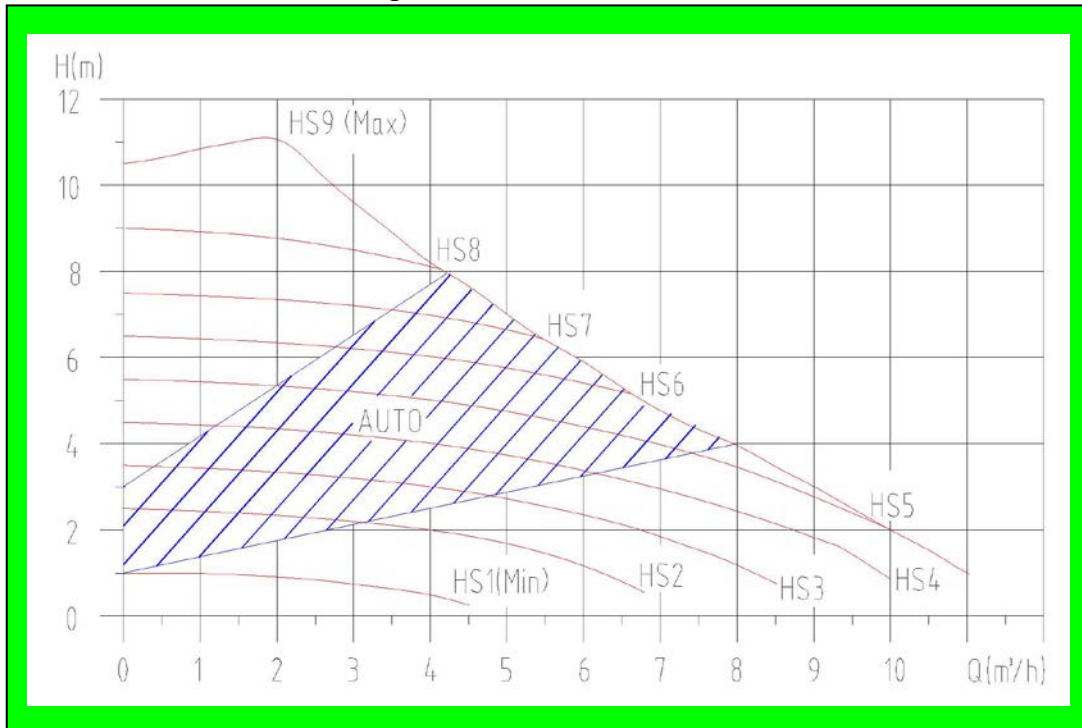

- Constant pressure mode performance curve

GPAXX-6 IV Constant Pressure Mode Performance Curve

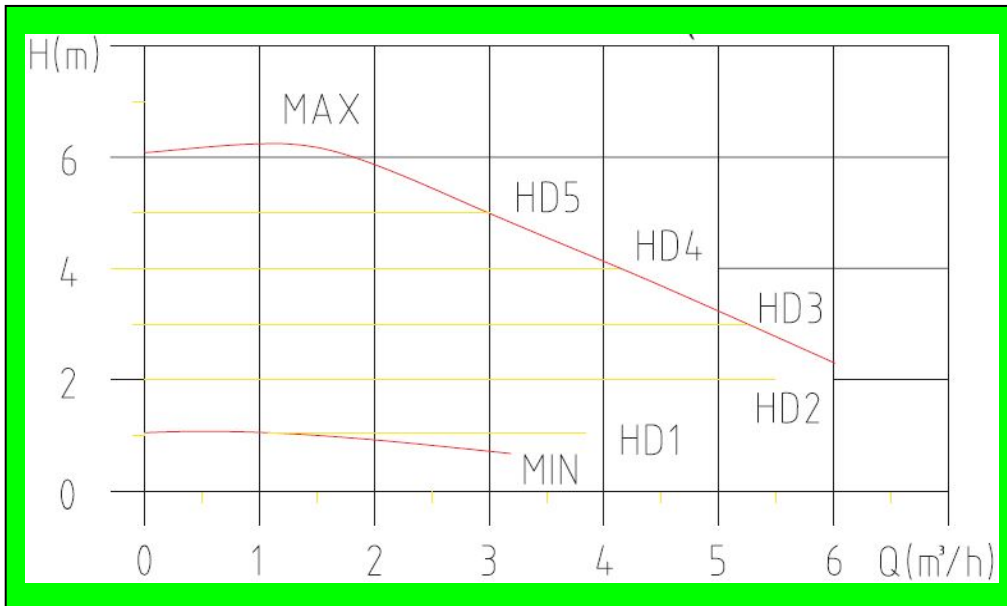

GPAXX-8 IV Constant Pressure Mode Performance Curve

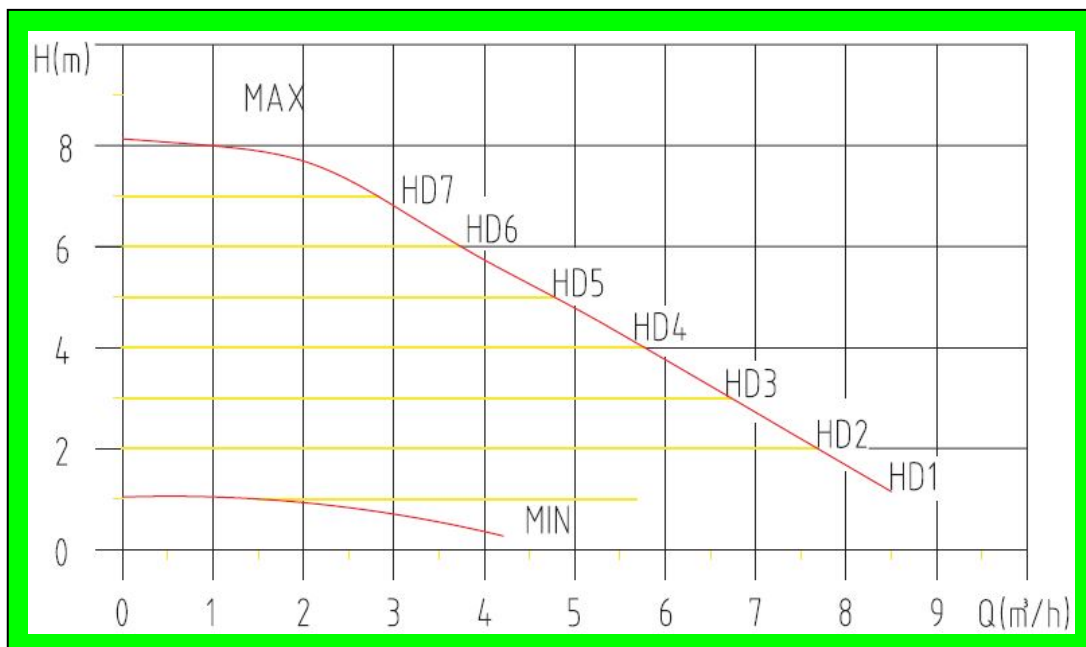

GPAXX-10 IV Constant Pressure Mode Performance Curve

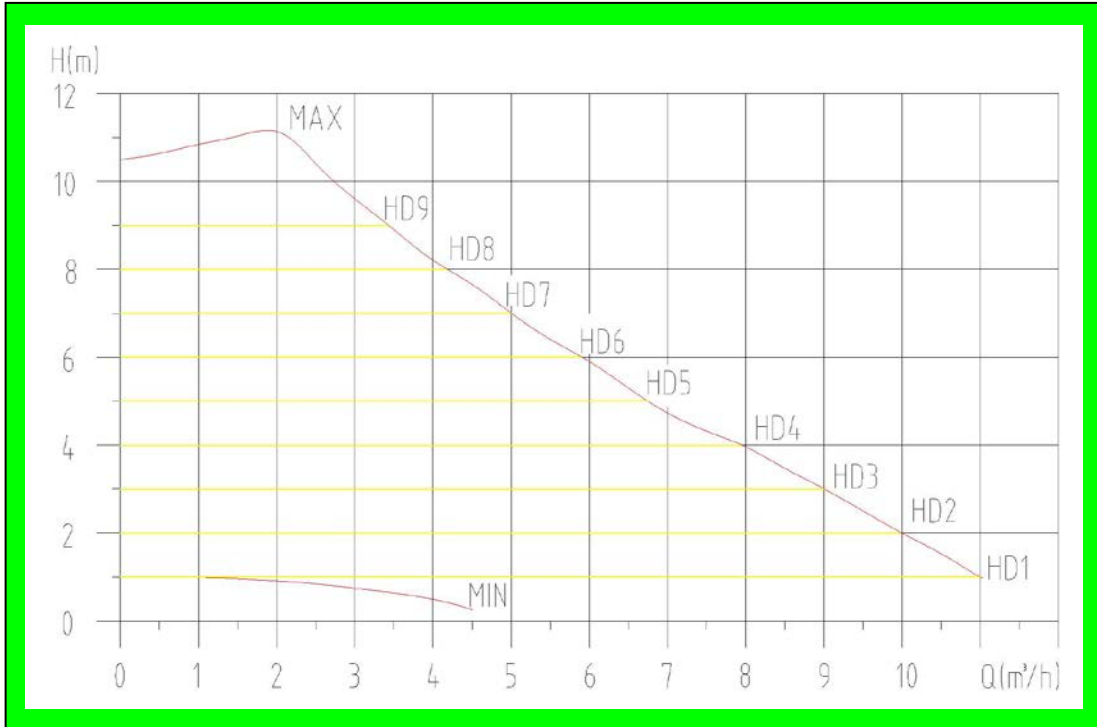

- Proportional pressure mode performance curve

GPAXX-6 IV Proportional Pressure Mode Performance Curve

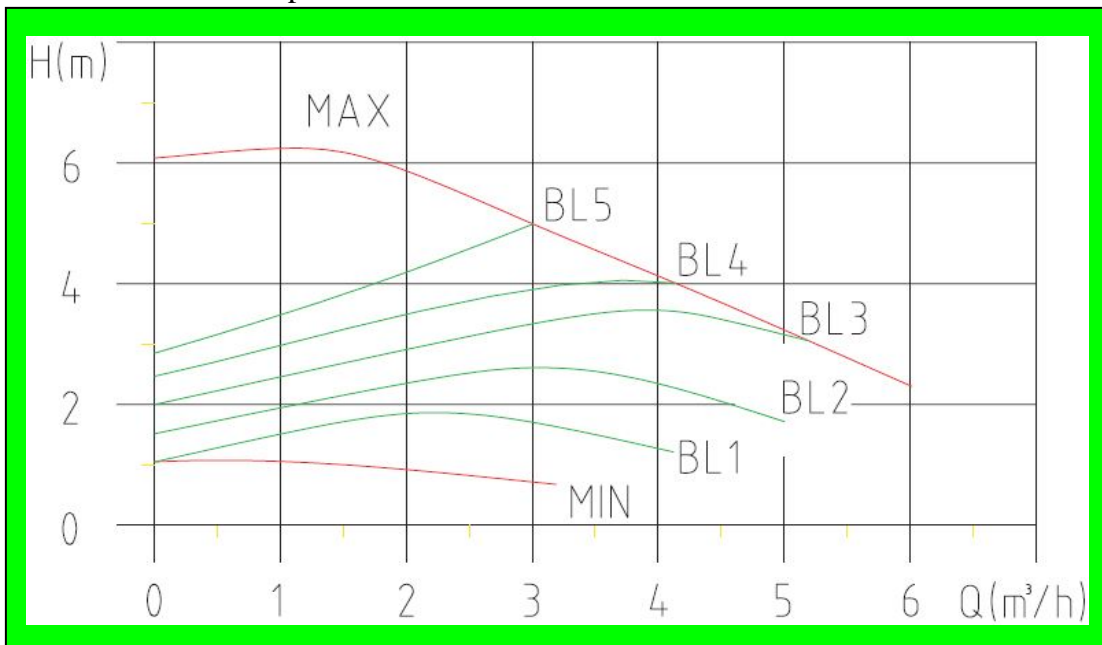

GPAXX-8 IV Proportional Pressure Mode Performance Curve

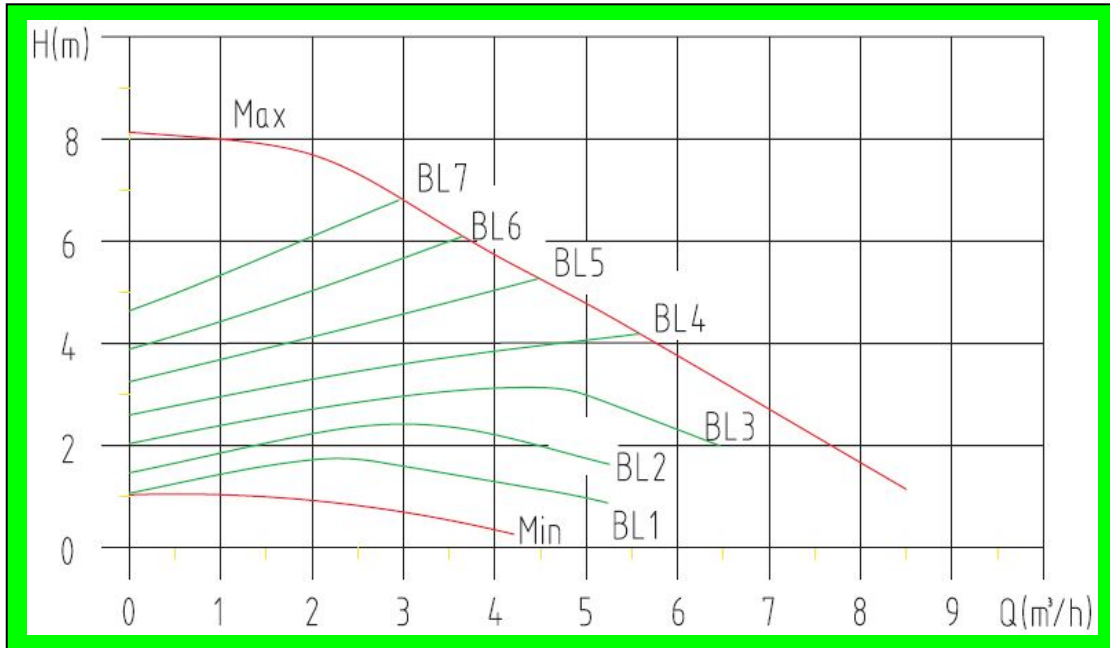

GPAXX-10 IV Proportional Pressure Mode Performance Curve

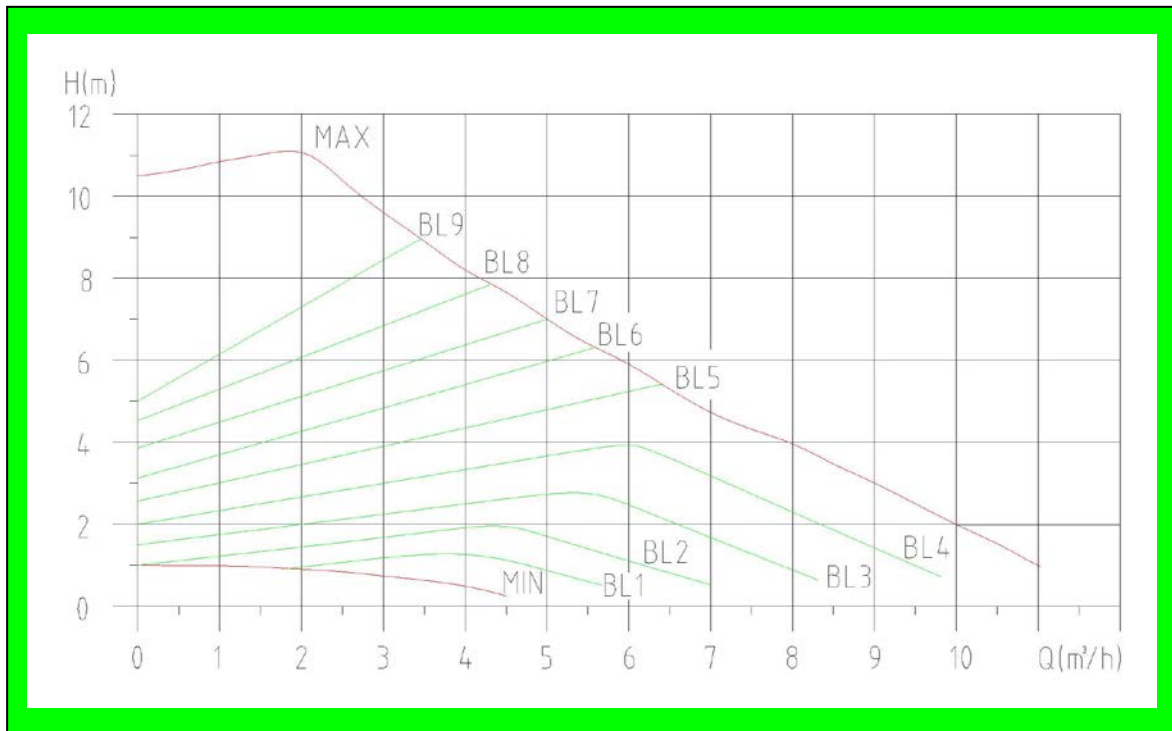

12. Features

12.1 Nameplate Instructions

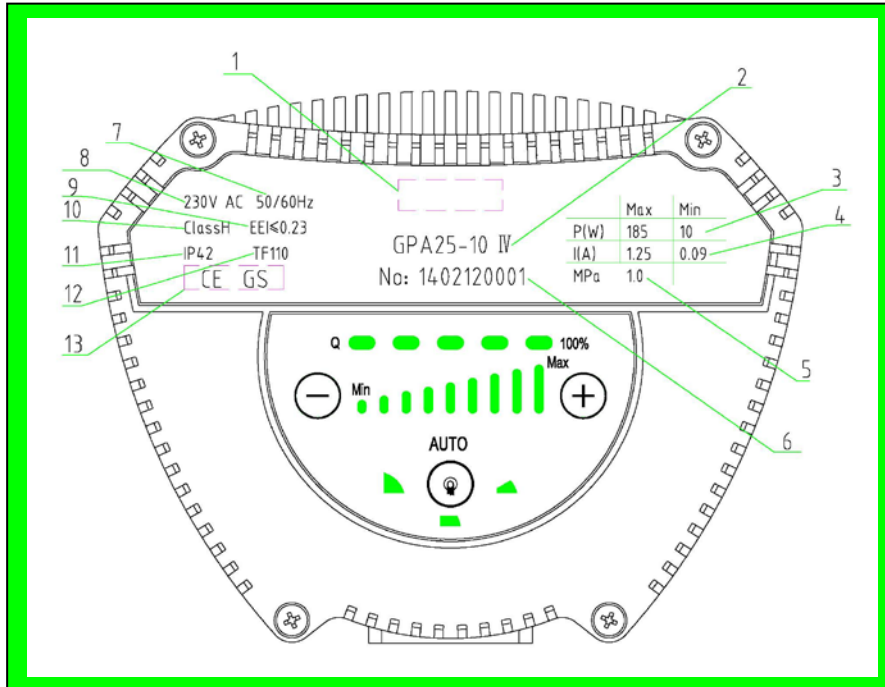

序号 No.	Descriptions	
1	Manufacturer Name	
2	Product Model	
3	Power (Watt)	Minimum mode minimum input power P1
		Maximum mode maximum input power P1
4	Current (Amp)	Minimum mode minimum current
		Maximum mode maximum current
5	Maximum system load bearing (Mpa)	
6	Date	Digit 1 to digit 6 indicates manufacturing date
	No.	Digit seven to digit ten indicates serial number
7	Frequency (Hz)	
8	Voltage (v)	
9	Energy Index	

10	Insulation class
11	Degree of protection
12	Temperature class
13	Authentication mark

12. 2 Model Instructions

the model of motor pump is composed of capitalized Latin letters and Arabic numbers, which means:

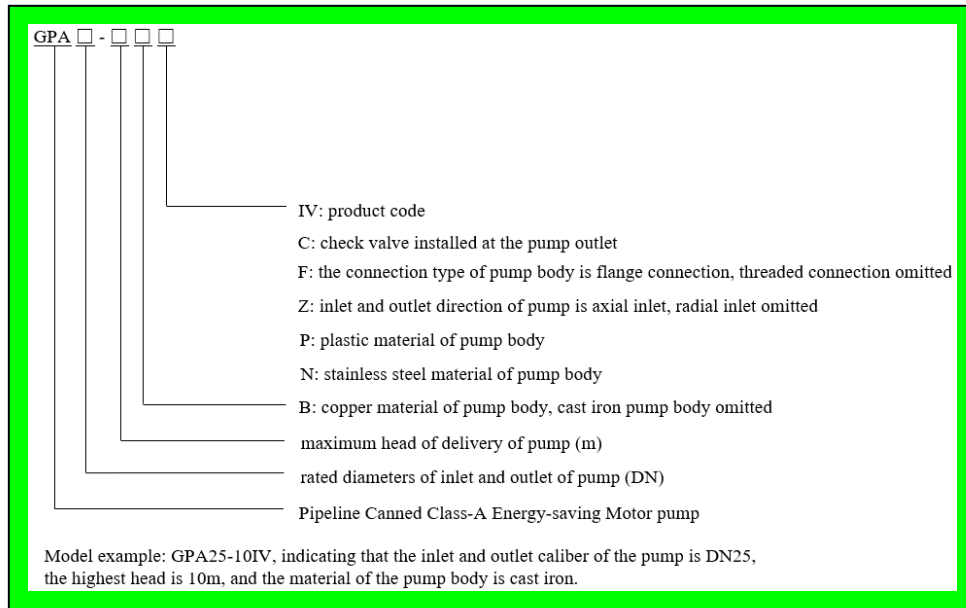

13. Technical Parameters and Installation Dimensions

13.1 Technical Parameters

Power Supply Voltage	1 × (220~240)V +6%/-10%, 50/60Hz	
Motor Protection	the pump needs no external protection	
Degree of Protection	IP42	
Insulation Class	H	
Relative Humidity (RH)	Max. 95%	
System Load Bearing	1.0 MPa	
Suction Port Pressure	Liquid Temperature	Minimum Inlet Pressure
	≤+85°C	0.005 MPa
	≤+90°C	0.028 MPa
	≤+110°C	0.100 MPa
EMC Standard	EN61000-6-1 与 EN61000-6-3	
Sound Pressure Class	The sound pressure level of pump is lower than 43dB (A)	
Ambient Temperature	0~+40°C	
Temperature Grade	TF110	
Surface Temperature	The maximum surface temperature is not higher than +125°C	
Liquid Temperature	2~+110°C	

To prevent condensation in the junction box and rotor, the temperature of pumping liquid of the motor pump must be always higher than ambient temperature.

Ambient Temperature (°C)	Liquid Temperature	
	Min.	Max.
0	2	110
10	10	110
20	20	110
30	30	110
35	35	90
40	40	70

For domestic hot water, it is suggested that water temperature should remains below 65 °C reduce scaling.

13. 2 Installation Dimensions

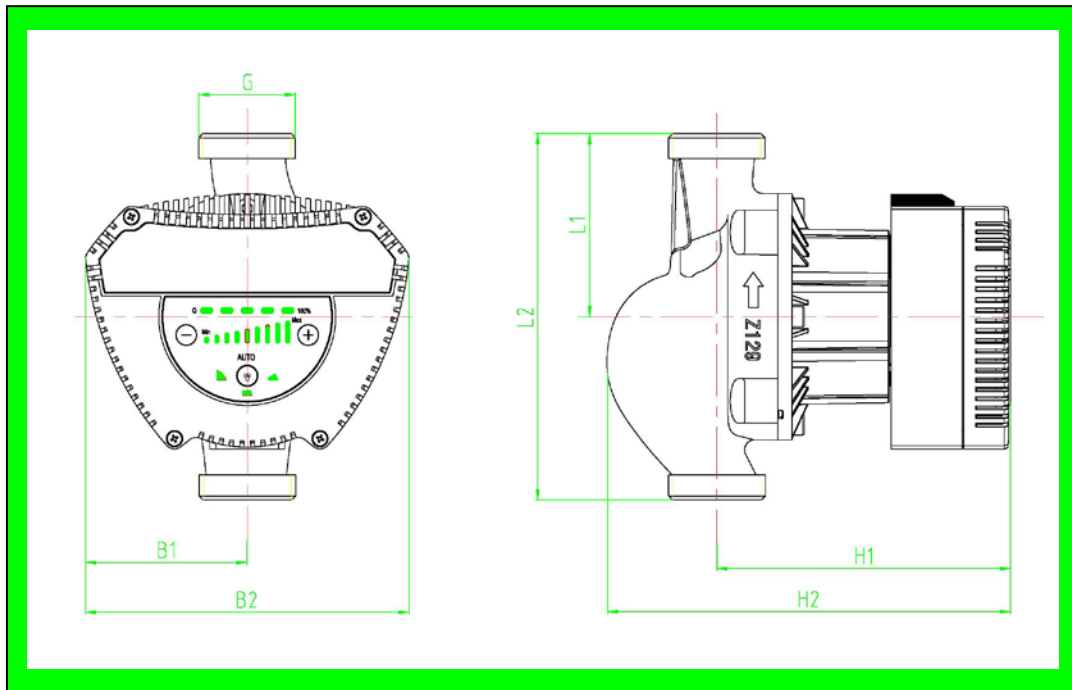

Power (W)	Product Model	Dimension(mm)						
		L1	L2	B1	B2	H1	H2	G
185	GPA25-10 IV	90	180	80	160	144	199	1 1/2"
	GPA32-10 IV	90	180	80	160	144	199	2"

14. Trouble-Shooting Schedule



Warning

Before conducting any maintenance and repair of the motor pump, ensure that power supply has been cut off and will not be connected accidentally.

Symptom	Control Panel	Corrective Action
Motor pump cannot be started	Equipment fuse burned	Replace the fuse
	the circuit breaker of current control or voltage control opens	connect the circuit breaker
	Failure of motor pump	Replace the motor pump
	Under voltage	inspect whether power supply is in specified range
	Motor pump blockage (blocked)	remove sundries
Noise in the system	Air exists in the system	vent the system
	excessively high flow rate	lower inlet pressure of the motor pump
Noise in the motor pump	Air exists in the motor pump	vent the system
	excessively low inlet pressure	raise inlet pressure
Insufficient heat	poor performance of motor pump	raise inlet pressure of motor pump

Hefei Xihu Product Warranty

Hefei Xihu Canned Motor Pump Co., Ltd offers 12 months of quality warranty for its products since the date of sales, and is responsible for product malfunctions or damaged due to manufacturing and material defects. This warranty is valid only when the product is installed strictly in accordance with *Xihu Installation and Operation Manual* and certified operation practices.

This warranty is not applicable to product malfunctions or damage due to ① use in any other purpose other than that recommended by Xihu company; ② failure of compliance with *Xihu Installation and Operation Manual* in the use of product; ③ inappropriate repair or moving of the product; ④ dismantling the product and/or replacing parts by themselves.

Any product supplied but not manufactured by Hefei Xihu Canned Motor Pump Co., Ltd shall comply with the quality warranty terms and conditions specified by its manufacturer.

During the warranty period, the user can have the product repaired with purchase invoice and warranty card. Please deliver or send the product to your vendor or designated repair center of Hefei Xihu Canned Motor Pump Co., Ltd for repair. Hefei Xihu Canned Motor Pump Co., Ltd can decide whether to offer free home repair according to the local repair policies. The repair of parts and components within warranty period is free of charges.

Hefei Xihu Canned Motor Pump Co., Ltd does not accept claims for damages due to third party liability or malfunctions caused by products of other companies.

Hefei Xihu Canned Motor Pump Co., Ltd will not be liable for product malfunctions or damage due to abnormal operation

conditions, war, riot, wind (rain) storm, disaster or other force majeure.

Hefei Xihu Canned Motor Pump Co., Ltd reserves the right to interpret any matters unmentioned in this product warranty.